

# ONYX

## MEASURING ARM

and Skyline scanners



A BETTER DEFINITION  
OF 3D MEASUREMENT

*Kreon*®

# THE MOST ACCURATE KREON MEASURING ARM

The Kreon Onyx measuring arm is the epitome of high performance. It guarantees 3D measurements of parts and tools with an unprecedented level of accuracy.

## Quality assurance

The use of high resolution encoders gives it the highest accuracy of all Kreon measuring arms. The presence of numerous carbon fiber structural parts makes the arm considerably lighter, which improves the user experience. Finally, the simplified and more rigid assembly of the Onyx arm makes it extremely reliable and durable, for flawless measurement results, even in the most challenging environments.

Meets all 3D measurement needs

Being versatile, Onyx arms are able to measure by probing or by scanning. They are equally suitable for use in a measuring lab or workshop and for all applications (quality control, reverse engineering, etc.). Thus, they will be a welcome addition across all industries (automotive, aerospace, etc.). Its light weight and ergonomic design provide an unparalleled ease of use and productivity.

Productivity  
Flexibility  
Reliability  
Trust  
Simplicity



# BETTER ERGONOMICS FOR GREATER PRODUCTIVITY

## Lightness and comfort

Onyx allows any user to work for hours with no effort, owing to its light handling and flexible counterbalancing.

Users particularly appreciate Kreon's internal counterbalancing that provides the perfect balance between firmness and flexibility. A lighter arm makes the use even more comfortable.

1 kg

Weight in your hand

9 kg

Full weight of the arm\*

\*Depending on the arm size



## Ergonomy and simplicity

Thanks to the ease and simplicity of use of the Onyx arm, beginner users are quickly operational.



## Fast mounting of the most appropriate configuration for scanning or probing

You can choose the best acquisition method according to the type of parts. At any time, and without recalibration, simply switching from probing to scanning.

The probing mode is more suitable for dimensional inspection of precise small geometric areas. The scanning mode is more suitable for the general shape of the part. And all of that without workflow interruption.

## Infinite rotation axes

Infinite rotation axes offer immense freedom of movement for users and allow measurements in cavities and areas that would otherwise be inaccessible.

Comfort  
Lightness  
Handling  
Speed

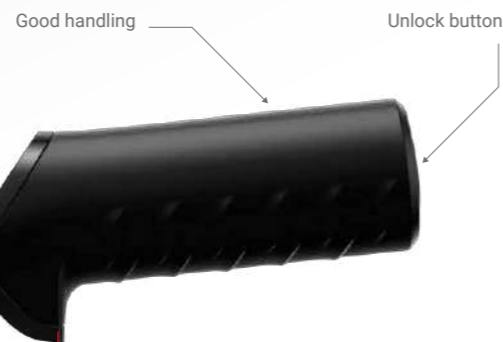

## EasyClip removable handle for increased flexibility

The handle of the Onyx 7-axis arm can be removed to allow measurement in cavities and areas that would otherwise be inaccessible. The handle is attached and removed simply by pressing the unlock button.

# NEW QUICKVIEW SCREEN

Clear visualisation and easy control of the main arm settings.



## | Battery charge



- ▶ Probing autonomy: 8 hours
- ▶ Scanning autonomy: 4 hours
- ▶ Batteries can be changed without stopping the measuring arm

## | Ambient temperature

25.2

- ▶ Prevent use outside normal operating temperatures (10-45°C)
- ▶ Compensate for the expansion of parts during significant temperature variations

## | Arm status



- ▶ Check that the arm is 100% operational or detect potential anomalies

## | Wifi and Bluetooth



- ▶ Easily use the arm far away from the computer thanks to the integrated wireless connection.

# A 6-AXIS VERSION FOR GREATER ACCURACY

The Onyx measuring arm is also available in a 6-axis version for probing use. It is mainly intended for measuring demanding geometric entities and even more accurate than the 7-axis version.



## | Exceptional accuracy

The 6-axis version of the Onyx arm is up to 20% more accurate than the 7-axis version. It is the most accurate in the Kreon range.

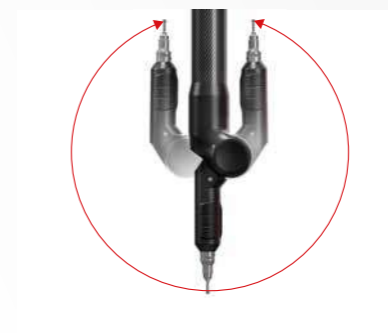

## | Freedom of movement

6th axis is extremely mobile with an impressive 360° range. It can easily reach the underside of certain assemblies or the inside of rabbets.



## | Probing difficult-to-access areas

The interior of certain parts, impossible to measure with tracked tools, can easily be reached with the fineness of the arm's ending.

# AN ULTRA PORTABLE SYSTEM

The Onyx measuring arm can be installed as close as possible to the application. Workshop, measuring lab or even outdoors, the arm can be used in the most extreme environments while maintaining measurement quality.

Fully wireless, lightweight and delivered with a transport case, the system is very easy to move. There is no need to pre-heat, it is instantly operational.

- ▶ Wireless probing and 3D scanning (WiFi or Bluetooth)
- ▶ Change the battery without turning off the system
- ▶ Accurate compensation of the ambient temperature
- ▶ Brunson universal attachment
- ▶ Fast installation, no pre-heating

## Fully wireless



Wifi



Bluetooth



Battery

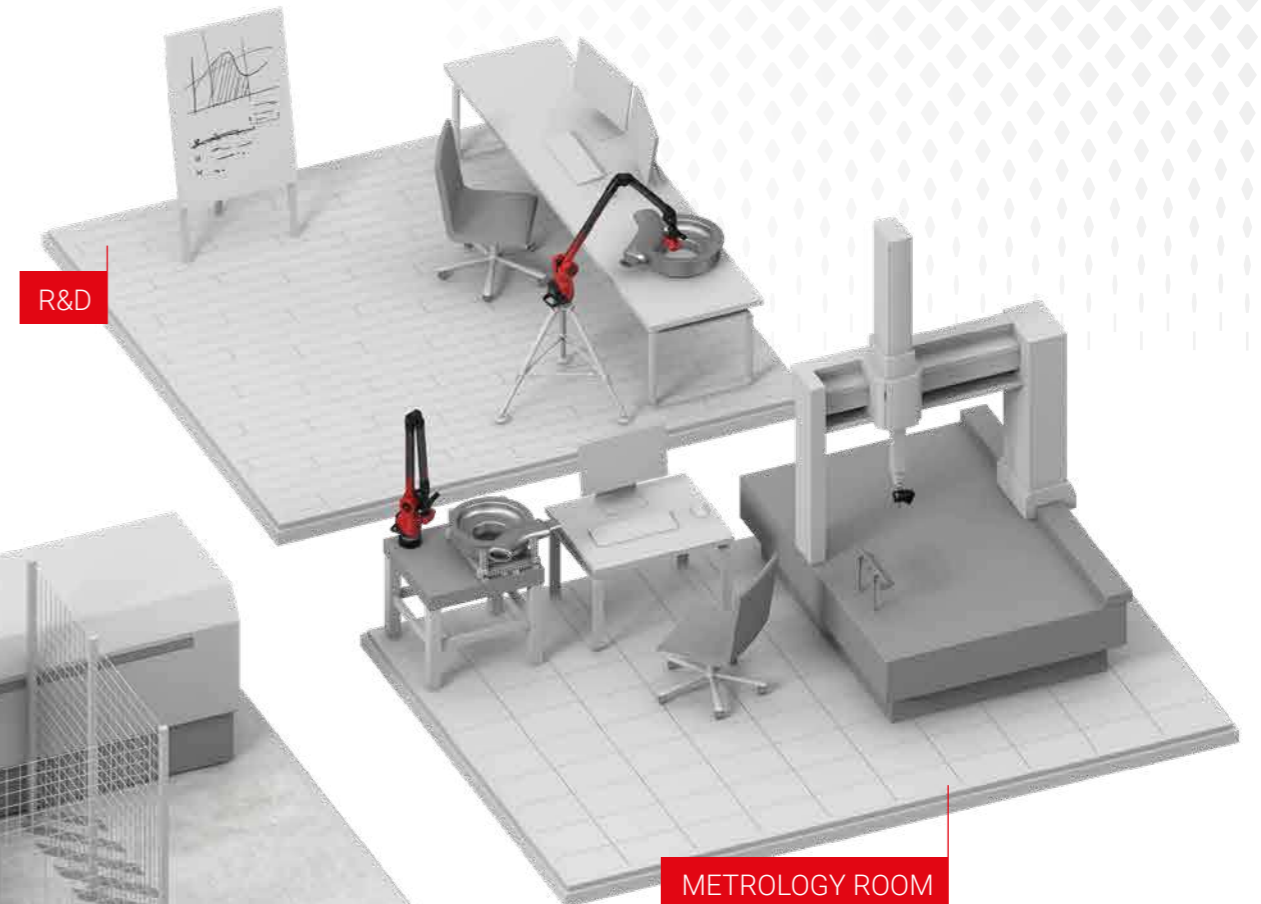
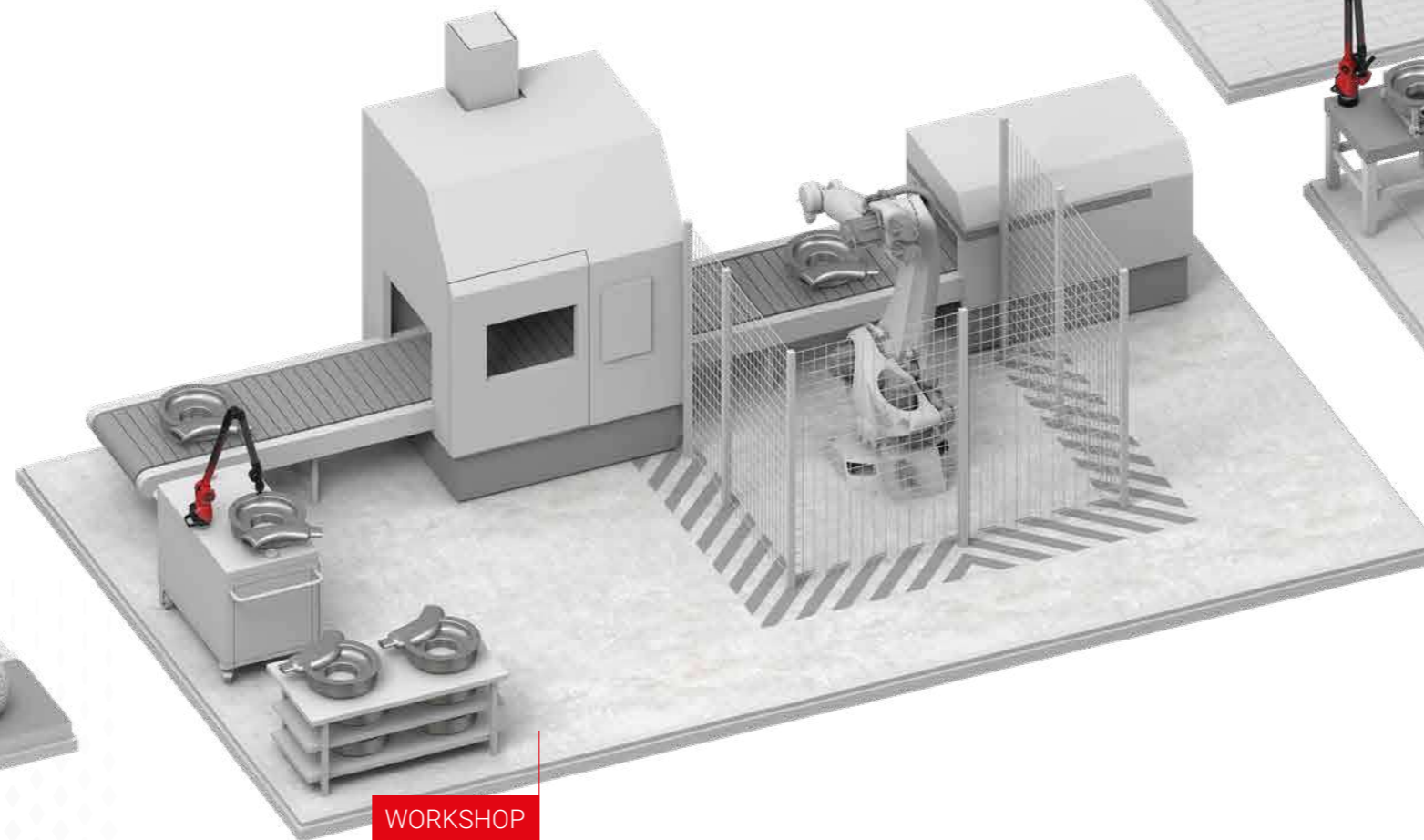
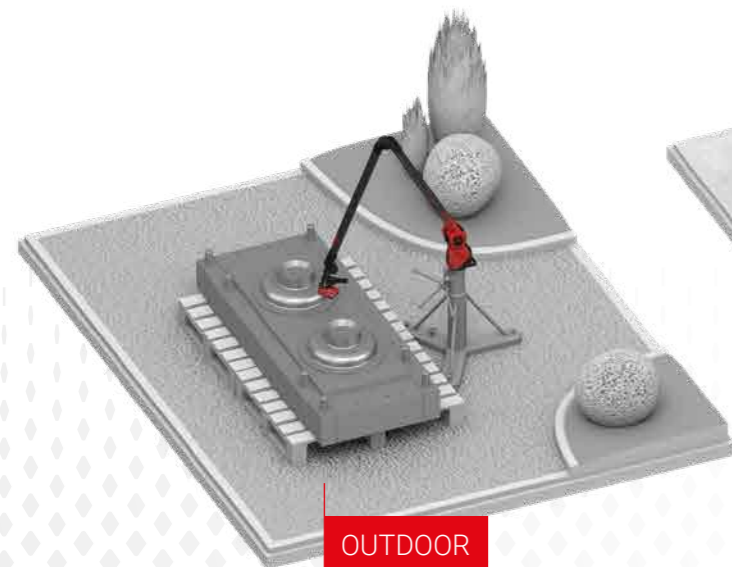

Portability  
Reliability  
Adaptability  
Lightness

# SKYLINE SCANNERS: SPEED AND ACCURACY

Skyline scanners use state-of-the-art technologies developed by KREON for nearly 30 years. Apart from leading technical capabilities, they are highly reliable, compact and adapt to almost any working environment.

Based on a single technology platform, Skyline 3D scanners are available in four models: Skyline **Eyes**, **Wide**, **Xtra Wide** and **Open**.

## SKYLINE EYES

The most accurate



is suited for the most challenging parts and applications

## SKYLINE WIDE

The fastest



is wide-awake to scan large surfaces at high speed

## SKYLINE OPEN

The most affordable



is open to any kind of project and application



Available with two laser line widths  
 Skyline Wide : 200 mm  
 Skyline Xtra Wide : 300 mm

To better capture reality, keep  
**“EYES WIDE OPEN”**

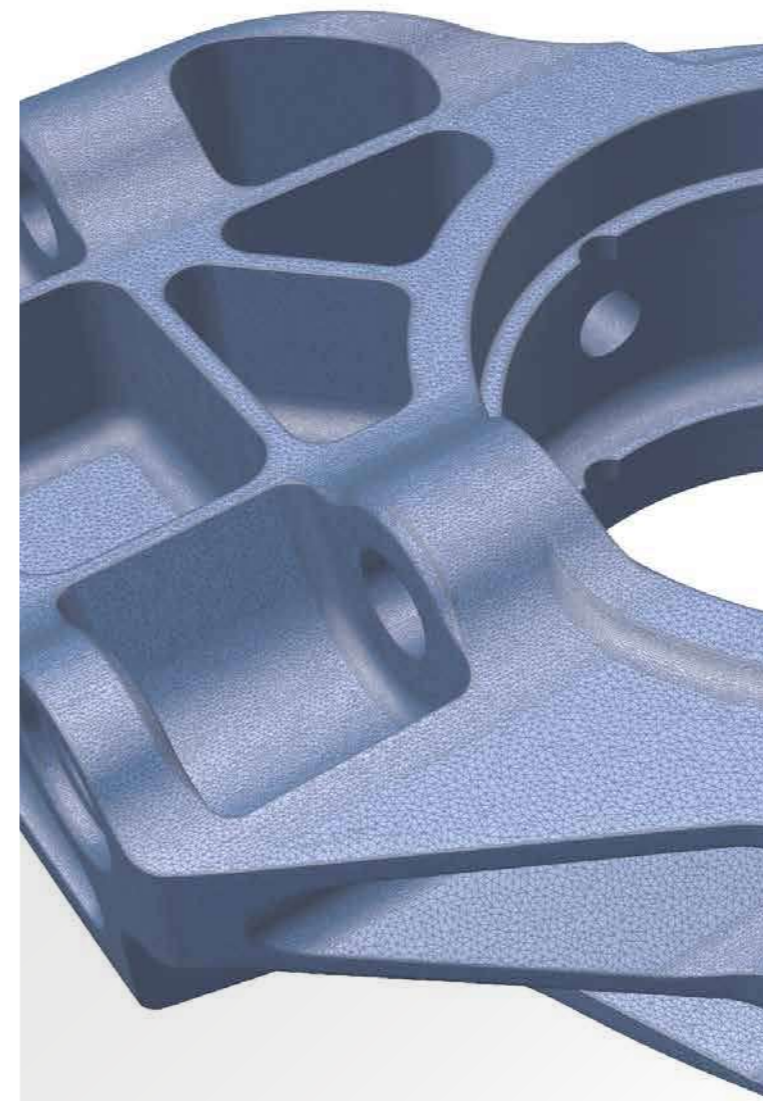

## Advanced scanning speed: 300mm\* laser line

- ▶ Less scan passes with 300mm laser line\*
- ▶ Faster movement of the 3D scanner assured by the increased frequency
- ▶ Acquisition speed of 600,000 points/sec, allowing to quickly get the dense point cloud\*

## High resolution: 25 μm\* High accuracy: 9 μm\*

- ▶ 2,000 points per laser line for a high resolution level\*
- ▶ Optimal accuracy, even on shiny reflective surfaces, due to blue laser fineness
- ▶ Temperature compensation of the 3D scanner to avoid pre-heating and to maintain a constant accuracy

## Easy of use

- ▶ Scan longer owing to the 3D scanner lightness (less than 400 g)
- ▶ Reach and scan the hard-to-access zones of each part, thanks to compactness
- ▶ Visualize precisely the ideal scanning distance with the LED indicators
- ▶ Remove the scanner rapidly and without any tool to accelerate the probe mounting

Software used for probing and scanning:  
 Zenith, Polyworks, Metrolog, Geomagic, PowerInspect, Capps, etc

\*maximum values depending on the Skyline scanner model  
 Technical specifications at the end of the documentation

Quality  
 Control  
 Accuracy  
 Performance

# APPLICATIONS

Kreon fulfills the needs and expectations of demanding customers regarding quality control, 3D measurement, deviation viewing, by providing highly effective measurement solutions for many years.

Always the best 3D acquisitions with the **Onyx** measuring arm

## Applications

- Quality control
- Rapid prototyping
- CAD comparison
- Reverse engineering
- Surface acquisition

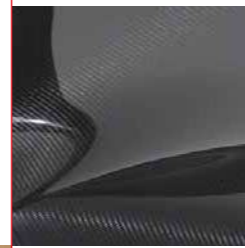

## Specialities

- Plasturgy
- Die and mold
- Sheet metal
- Stamping parts
- Foundry
- Milling

## Industries

- Automotive
- Aeronautics
- Goods industry
- Education
- Heritage

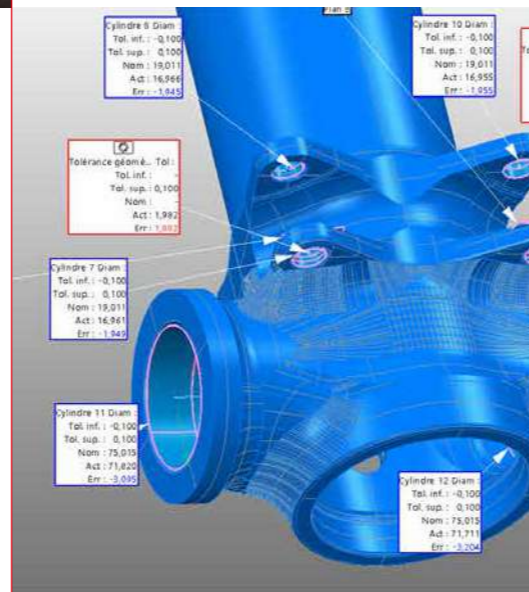
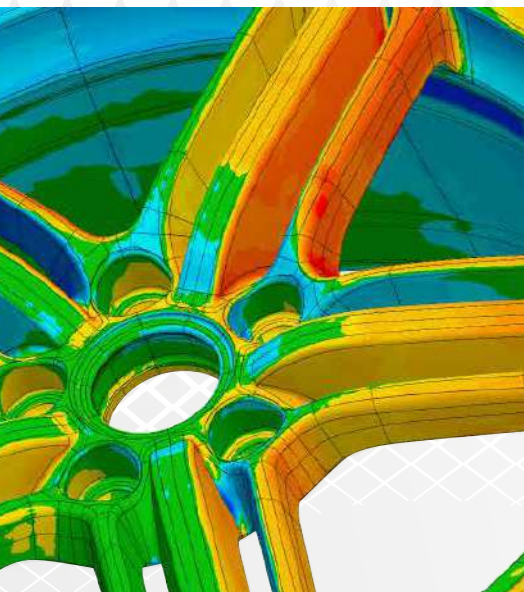

# ZENITH SOFTWARE: EASILY MANAGE SCANNING AND PROBING

Zenith focuses on the essential functions used in most applications for acquisition and 3D measurement of industrial parts. Simple to learn but able to manage dense point clouds and create color mapping, this is Zenith.

### Connection with Kreon hardware

#### Probing

- Acquisition of geometrical entities
- Measure and deviation

#### 3D scanning

- Fast point cloud acquisition
- Extraction from CAD
- Color mapping

#### Automatic report generation



# ACCESSORIES

Kreon offers a wide range of accessories for adapting the configuration of the measuring arm to the application and the working environment: specific probes, mounting bases, tripods, leapfrog kit.



Probes



Bases



Leapfrog kits



Lightweight tripods



Heavy tripods



Rolling carts

# TECHNICAL SPECIFICATIONS

## Onyx measuring arms

	Arm model	Working volume	E <sub>UNI</sub> *	P <sub>SIZE</sub> *	P <sub>FORM</sub> *	L <sub>DIA</sub> *	SPAT*
7 AXIS	Onyx-7-20	2 m	0.025 mm	0.010 mm	0.018 mm	0.040 mm	0.020 mm
	Onyx-7-25	2.5 m	0.028 mm	0.011 mm	0.021 mm	0.044 mm	0.023 mm
	Onyx-7-30	3 m	0.050 mm	0.016 mm	0.028 mm	0.072 mm	0.035 mm
	Onyx-7-35	3.5 m	0.061 mm	0.020 mm	0.035 mm	0.087 mm	0.043 mm
	Onyx-7-40	4 m	0.074 mm	0.025 mm	0.040 mm	0.102 mm	0.052 mm
	Onyx-7-45	4.5 m	0.100 mm	0.038 mm	0.049 mm	0.110 mm	0.065 mm
	Onyx-7-50	5 m	0.120 mm	0.052 mm	0.062 mm	0.125 mm	0.089 mm
6 AXIS	Onyx-6-20	2 m	0.024 mm	0.007 mm	0.015 mm	0.030 mm	0.017 mm
	Onyx-6-25	2.5 m	0.026 mm	0.008 mm	0.016 mm	0.032 mm	0.019 mm
	Onyx-6-30	3 m	0.038 mm	0.012 mm	0.022 mm	0.046 mm	0.028 mm
	Onyx-6-35	3.5 m	0.051 mm	0.015 mm	0.030 mm	0.062 mm	0.035 mm
	Onyx-6-40	4 m	0.062 mm	0.020 mm	0.036 mm	0.078 mm	0.042 mm
	Onyx-6-45	4.5 m	0.072 mm	0.024 mm	0.041 mm	0.090 mm	0.057 mm
	Onyx-6-50	5 m	0.110 mm	0.038 mm	0.058 mm	0.110 mm	0.080 mm

## Onyx measuring arms with Skyline scanners

Arm model	ONYX			
	Skyline Eyes	Skyline Wide	Skyline Xtra Wide	Skyline Open
Onyx-7-20	0.038 mm	0.042 mm	0.054 mm	0.044 mm
Onyx-7-25	0.040 mm	0.044 mm	0.056 mm	0.047 mm
Onyx-7-30	0.050 mm	0.055 mm	0.067 mm	0.057 mm
Onyx-7-35	0.064 mm	0.069 mm	0.081 mm	0.072 mm
Onyx-7-40	0.075 mm	0.079 mm	0.091 mm	0.082 mm
Onyx-7-45	0.093 mm	0.102 mm	0.114 mm	0.109 mm
Onyx-7-50	0.120 mm	0.130 mm	0.142 mm	0.140 mm

### L<sub>DIA</sub> Scanning\*

Operating temperature range: 10-45 °C  
 Power supply: universal worldwide voltage 100-250V  
 Humidity: 95%, non condensing  
 IP51

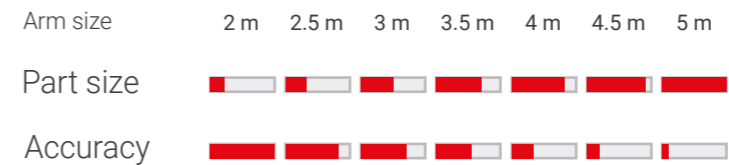

## Skyline specifications

	EYES	WIDE	XTRA WIDE	OPEN
Max scanning speed	600.000 pts/sec	600.000 pts/sec	600.000 pts/sec	200.000 pts/sec
MPE (P[Size.Sph.All:Tr:ODS]) (2σ) *1	9 μm	15 μm	28 μm	15 μm
MPL (P[Form.Sph.D95%:Tr:ODS]) (2σ) *2	15 μm	17 μm	31 μm	20 μm
MPL (P[Form.Pla.D95%:Tr:ODS]) (2σ) *3	18 μm	22 μm	36 μm	25 μm
Max laser line width	100 mm	200 mm	300 mm	100 mm
Max frequency	300 Hz	300 Hz	300 Hz	200 Hz
Laser line color	2M Blue	2M Blue	Blue	2M Blue
Line resolution	25 μm	50 μm	60 μm	50 μm
Stand-off distance	90 mm	85 mm	100 mm	85 mm
Field of view	80 mm	110 mm	135 mm	110 mm
LED indicators	Yes	Yes	Yes	No
Temperature compensation	Yes	Yes	Yes	No

## Onyx arms comply with ISO 10360-12

According to ISO 10360-12, 2016 :

- EUNI (EUni:0:Tact.AArm)**  
Unidirectional distance error between two probed points in the arm volume
- PSIZE (PSize.Sph.1x25:Tact.AArm)**  
Error on the measurement of a sphere diameter by probing
- PFORM (PForm.Sph.1x25:Tact.AArm)**  
Dispersion value in measurement of a sphere radius by probing
- LDIA (LDia.5x5:Art:Tact.AArm)**  
Errors due to arm articulations, mainly axes 5, 6 and 7 of the wrist, measured with probe
- SPAT**  
Measurement error when the probe is stationary and the arm elbow moves from left to right

## Skyline scanners comply with ISO 10360-8

According to ISO 10360-8:2013:

- LDIA scanning (LDia:j:ODS)**  
Errors due to arm articulations, mainly axes 5, 6 and 7 of the wrist, measured with scanner
- \*1 MPE (P[Size.Sph.All:Tr:ODS])  
Error on the measurement of a sphere diameter by Scanning
- \*2 MPL (P[Form.Sph.D95%:Tr:ODS])  
Dispersion value on 95% of the measured points on a sphere
- \*3 MPL (P[Form.Pla.D95%:Tr:ODS])  
Dispersion value on 95% of the measured points on a plan







# Digital Scan 3D

SYNCHRONIZING THE WORLD OF

**Contact us for a demo**  
**[info@DigitalScan3d.com](mailto:info@DigitalScan3d.com)**  
**Tel: +1 503.388.8888**  
**[www.DigitalScan3d.com](http://www.DigitalScan3d.com)**



**Digital Scan 3D LLC**  
2828 S Kelly Avenue,  
Portland OR 97201,USA  
E-mail : [info@DigitalScan3d.com](mailto:info@DigitalScan3d.com)